

Bus Isolated

PC104 Card

User's Guide

PCM_ADC16_A (PCM_1917A)

PCM_1917

16 / 8 Channels

Analog Input

Bus Isolated

PC104 Card

User's Guide

征集各位意见
深圳市汇方成科技

Features

The PCM1917 Isolation Data Acquisition Card provides the following advanced features:

- PC104 Bus
- 12-bit analog input resolution
- On-board A/D 1024 word FIFO memory (build in FPGA)
- Up to 100KHz A/D sampling rates
- Isolation voltage: 2500Vrms
- 16 single-ended or 8 differential analog input channels
- Bipolar or Unipolar input signals
- Programmable Gain Control (x1, x2, x5, x10)
- 4 digital Isolation output channels
- 4 digital Isolation input channels
- Two A/D trigger modes:
 - software trigger, programmable pacer trigger,
- Integrated DC-to-DC converter for stable analog power source
- 37-pin D-type connector for PCM1917A

Specifications

Analog Input (A/D)

- Converter : AD7895
- Resolution : 12-bit
- Numbers of Input Channel: 16 single-ended or 8 differential
- Input Range: (Programmable)
- ✓ Bipolar : $\pm 10V, \pm 5V, \pm 2V, \pm 1V$
- ✓ Unipolar: $+10V, +5V, +2V, +1V$
- Conversion Time: 5 μ sec
- sampling rates : 100KHz
- Analog Input Over-voltage Protection: Continuous $\pm 35V$ max.
- Accuracy: ± 2 LSB
- Input Impedance: 10 M Ω
- Trigger Modes: Software, Timer Pacer
- Data Transfer Modes: Program polling control
- Isolation voltage: 2500Vrms
- FIFO Depth: 1024 words

• **Isolated Digital Output**

- Number of channels: 4 channels
- Electricity characteristics: Open collector transistor
- Output Voltage: open collector 5V (min) to 40 VDC (max)
- Sink Current: Max. 50mA
- Isolation Voltage: 2,500 VDC
- Max. Throughput: 10KHz

• **Isolated Digital Input**

- Number of channels: 4 channels
- Electricity characteristics: Non-polarity photo-coupler
- Input Voltage: 0 - 24VDC or -24VDC - 0
Logic H: 3~24V or -24~-3V
Logic L: 0~2.4V or -2.4V~0
- Input Resistance: 4.7k Ω Ohm @ 0.25W
- Isolation Voltage: 2,500 VDC
- Max. Throughput: 10KHz

Base Address Setting

The PCM1917A requires 16 consecutive address locations in I/O address space. The base address of the PCM1917A is restricted by the following conditions.

1. The base address must be within the range *Hex 200* to *Hex 3F0*.
2. The base address should not conflict with any PC reserved I/O address.
3. The base address must not conflict with any add-on card on your own PC104. Please check your PC104 before installing the PCM1917A. The PCM1917A's base address is selected by a 6 position DIP switch SW1. (only 5 position used) The default setting of base address is set to be **HEX 2c0**. All possible base address combinations are listed as Table . You may modify the base address if the address *HEX 2c0* has been occupied by another add-on card;

SW1 : Base Address = 0x2C0

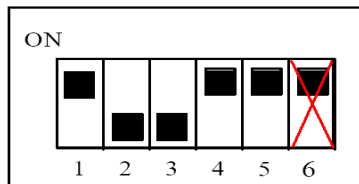

A (8 7 6 5 4 3)

Base Address Setting

I/O port address(hex)	fixed A9	1 A8	2 A7	3 A6	4 A5	5 A4
200-20F	OFF (1)	ON (0)	ON (0)	ON (0)	ON (0)	ON (0)
210-21F	OFF (1)	ON (0)	ON (0)	ON (0)	ON (0)	OFF (1)
:						
(*) 2C0-2CF	OFF (1)	ON (0)	OFF (1)	OFF (1)	ON (0)	ON (0)
:						
300-30F	OFF (1)	OFF (1)	ON (0)	ON (0)	ON (0)	ON (0)
:						
3F0-3FF	OFF (1)	OFF (1)	OFF (1)	OFF (1)	OFF (1)	OFF (1)

(*) : default setting ON : 0

X : don't care OFF : 1

Note: A4, ..., A9 correspond to PC bus address lines.

Pin Assignments

(For single-ended connection)

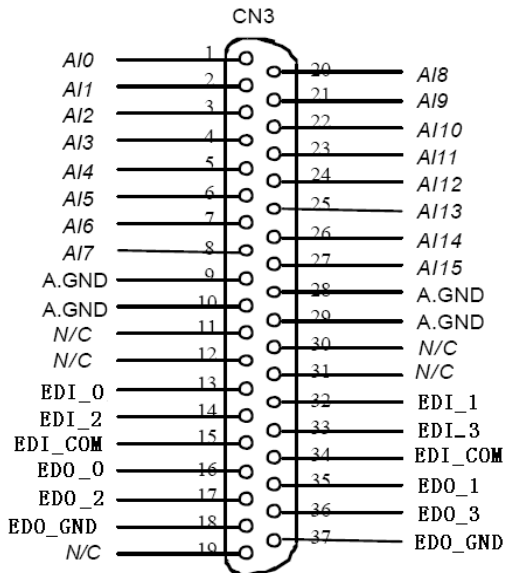

(For differential connection)

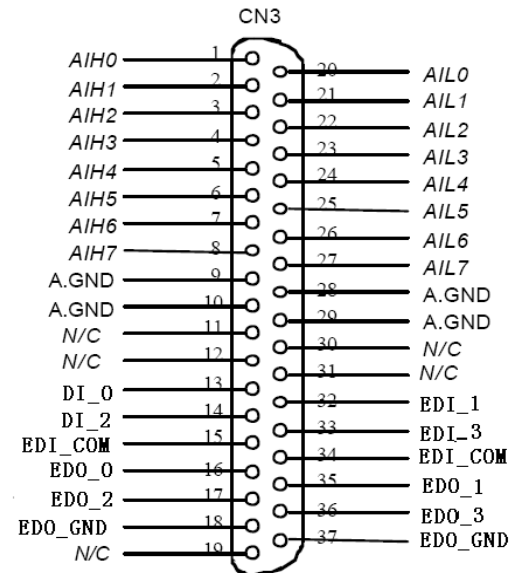

Legend:

AI n: Analog Input Channel *n* (single-ended)

AIH n: Analog High Input Channel *n* (differential)

AIL n: Analog Low Input Channel *n* (differential)

EDI_n: ISO Digital input Channel *n*

EDI_COM: COM of EDI

EDO_n: ISO Digital output Channel *n*

EDO_GND: COM of EDO_GND

Registers Format

The PCM1917 requires 16 consecutive addresses in the PC's I/O address space. The starting address (Base) is selected on the DIP switch SW1, The following table shows the location of each register and its description. The register write and read is 16bit mode ;

offset	name	Read Funtion	Write Funtion
0x0	DIO	Read Digital input	Write Digital ouput
0x2	Data/Command	AD Data from fifo	Trig /Channel Command
0x4	GAIN	Gain Control	Gain Control
0x6	TIMER Hight	Timer Hight Value	Timer Hight Value
0x8	TIMER Low	Timer Low Value	Timer Low Value
0xa	Fifo	Fifo Level	Fifo Deep
0xc	Counter	Sample Counter	Sample Counter
0xe	VID/PID	VID/PID	index

Analog Input Signal Connection

The PCM1917A provides 16 single-ended or 8 differential analog input channels. The analog signals can be converted to digital value by the A/D converter. To avoid ground loops and to obtain more accurate measurements, it is quite important to understand the signal source type and how to choose the analog input modes: signal-ended or differential. The PCM1917A offers jumpers to select 16 single-ended or 8 different analog inputs.

Single-ended Mode

The single-ended mode has only one input relative to ground and is suitable for connecting with a *floating signal source*. A floating source is one that does not have any connection to ground. Figure shows the single-ended connection. Note that when more than two floating sources are available, the source must be with common ground.

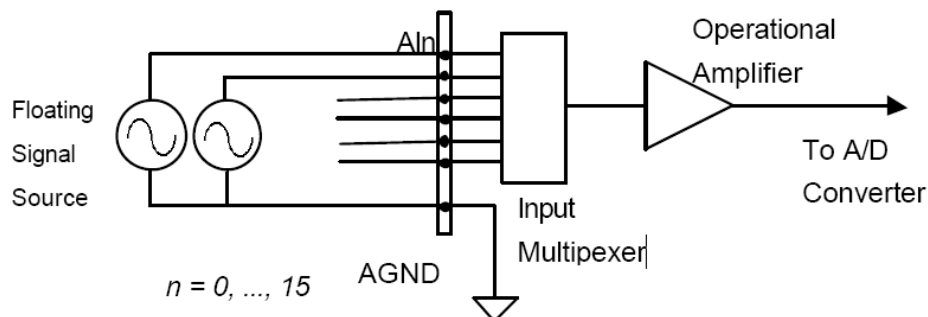

Floating source and single-ended

Differential input mode

The differential input mode provides two inputs that respond to differences in signals. If the signal source has one side connected to local ground, the differential mode can be used to reduce the effect of ground loops. Figure shows the connection for differential input mode. However, if the signal source is locally grounded, the single-ended mode can be used when the V_{cm} (Common Mode Voltage) is very small and the effect of ground loops is minimal.

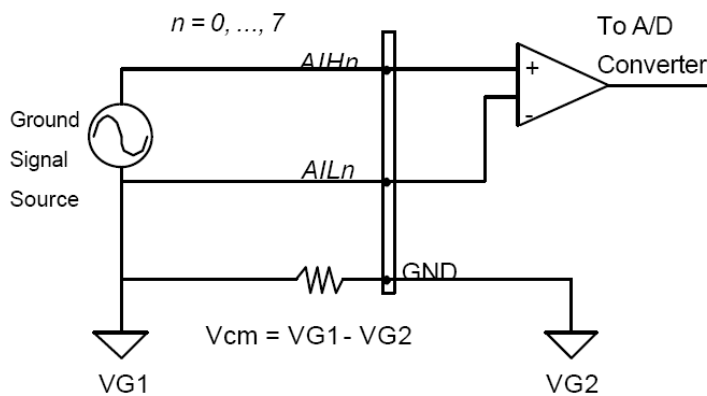

Ground source and differential input

A differential mode must be used when the signal source is differential. A differential source means that the ends of the signal are not grounded. To avoid the danger of high voltages between the local ground of the signal and the ground of the PC system, a shorted ground path must be connected. Figure shows the connection for a differential source.

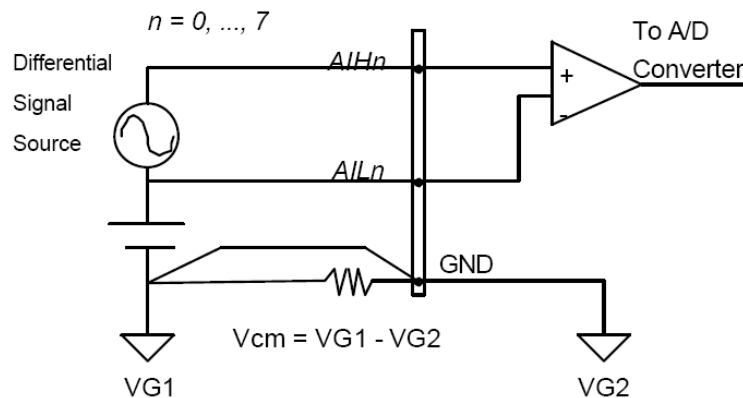

Differential source and differential input

If the signal source are both floating, you should use the differential mode, and the floating signal source should be connected as the Figure

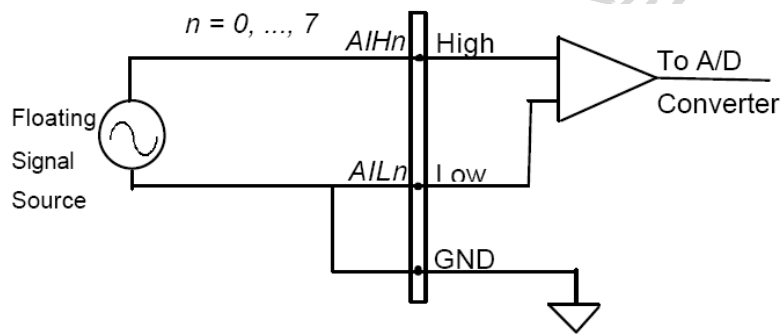

Floating source and differential input

Isolated Digital Input /output

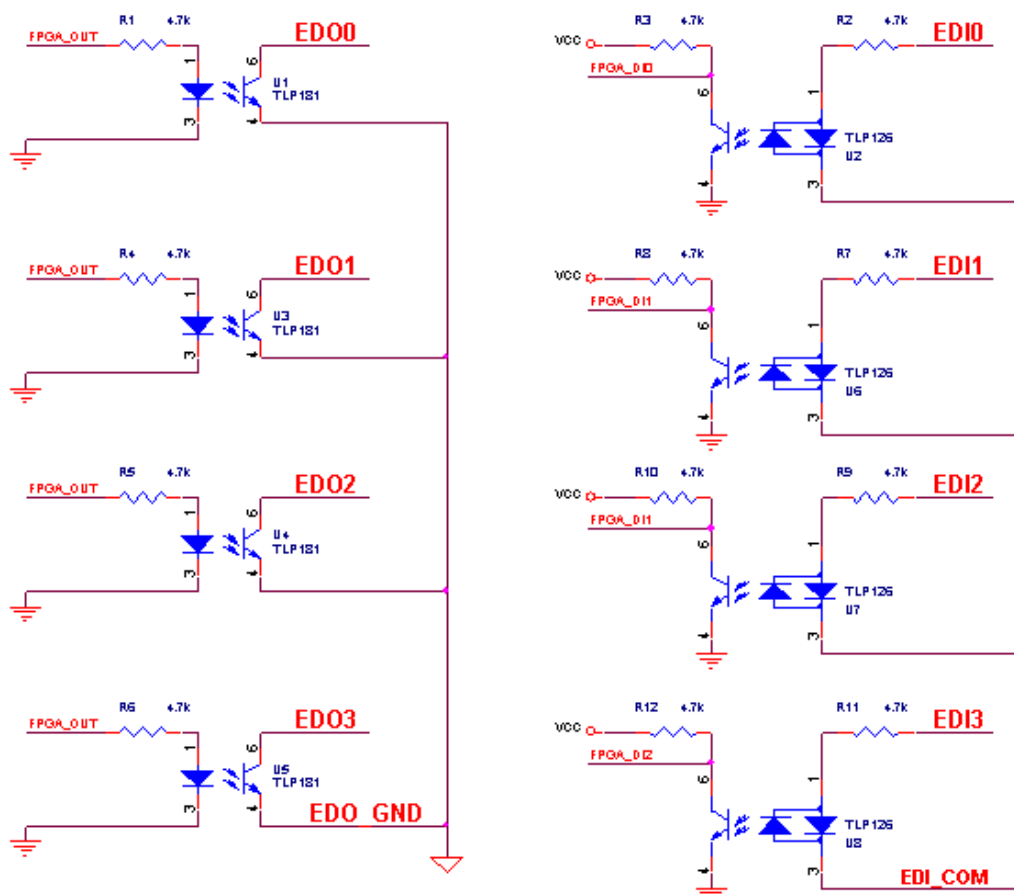

A/D Conversion Procedure

The A/D conversion starts when a trigger is set by the trigger source. The PCM1917 provides Two A/D trigger modes :software trigger, programmable pacer trigger, While A/D conversion is in progress, The converted data will be Write to fifo build in fpga .The A/D data should now be transferred into the PC's memory for further processing.

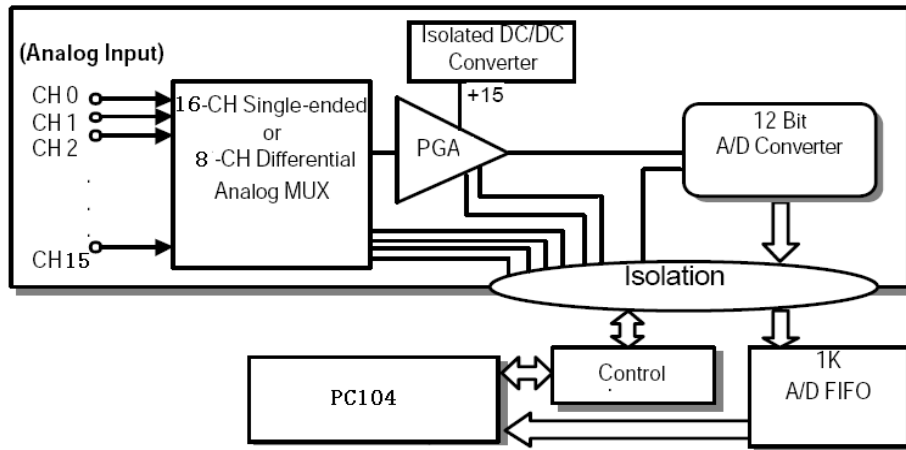

A/D Trigger Modes

In the PCM1917 , A/D conversion can be triggered by two source.

Software trigger

This trigger source is software controllable. That is, the A/D conversion starts when Command is written into the register . This trigger mode is suitable for low speed A/D conversions. Under this mode, the timing of the A/D conversion is fully controlled by the software. However, it is difficult to control a fixed A/D conversion rate unless another timer interrupt service routine is used to generate a fixed rate trigger.

Timer Pacer Fixd_Channel Trigger

An counter build in fpga is used to provide a trigger source for A/D conversion at a fixed rate and fixed channels. This mode is ideal for high speed A/D conversion. It's recommended that this mode be used if your application needs a fixed and precise A/D sampling rate.

Timer Pacer Scan_Channel Trigger

Auto Scan Trigger comman is used to provide a fixed rate and Scan the channel is: 0, 1, 2, 3, ... , [Maxchannel], 0, 1, 2, 3, ... [Maxchannel]. It's recommended that this mode be used if your application needs a fixed and precise A/D sampling rate and many channels .

A/D Data Transfer Modes

The A/D data are buffered in the FIFO memory. The FIFO size of the PCM1917 is 1024 words. If the sampling rate is 100 KHz, the FIFO can buffer 10.24 ms of analog signal. Data transferred to the FIFO after the FIFO is full will be lost. The software must read out the FIFO data before it becomes full. The data must be transferred to the host memory after the data is ready and before the FIFO is full.

The software polling is the easiest way to transfer A/D data. After the A/D conversion is start by command, the A/D data will be written to FIFO immediately, the *Fifo_deep* is the count of A/D . The software should polling the *Fifo_deep* register until it becomes greater than you want. Then The software can read out the FIFO data .

It is possible to read only one A/D converted data without polling. The A/D conversion time will not exceed $8\mu\text{s}$ on PCM1917 card. Hence, after software trigger, the software can wait for at least $10\mu\text{s}$ then read the A/D register without polling.

The data polling transferring is very suitable for applications that need to process AD data in real time. Especially when combining with the timer interrupt generation, the timer interrupt service routine can use the data polling method to get multi-channel A/D data in real time and under fixed data sampling rates.